

# NOERL

Marine hydraulic steering system

## INSTALLATION MANUAL





Thank you for purchasing NOERL hydraulic steering system.

This manual will elaborate the various functions of this system so that you can fully experience the premium enjoyment this product can bring you.

- NOERL hydraulic steering system is based on the concept of modern industrial design, the high efficiency, high transmission power piston pump technology is applied to the design and manufacture of ship steering gear, which makes your steering system more stable, smarter and more reliable.
- The main components of the steering gear are high strength aluminum alloy and stainless steel which can be used in harsh marine conditions and extend the longevity of steering gear.
- The steering gear will relieve you from the heavy and inflexible mechanical shaft steering, which can save your sore arms. It can enhance the pleasure of driving a speedboat.

## Main features:

- The steering pump is with compact inner structure and the fashionable and beautiful appearance.
- Two - way Built - in locking valve eliminates the rebound torque .
- Easy to replace the shaft seal ,user - friendly design;
- Steering shaft with special surface treatment not only has strength and reliability, but also has the characteristics of wear resistance, corrosion resistance.
- High - strength aluminum alloy shell and surface treatment process can ensure its wear and corrosion resistance and prevent water erosion effectively.
- Piping: High-strength nylon quick-fitting 1/4-pipe fittings makes the installation compact and it is reusable .
- The use of custom high -standard hydraulic oil can improve the lubrication of parts and seal protection .

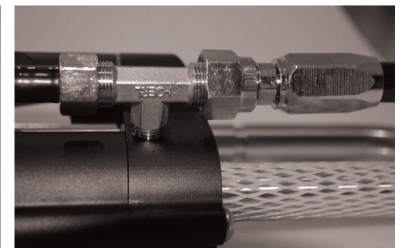
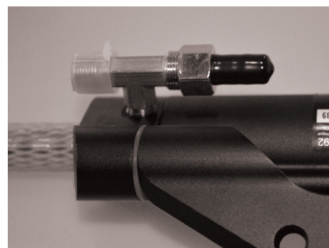



## INDIC

---

— General safety rules and warranty	pag . 2
— Safety rules	pag . 2
— Installation notes	pag . 2
— Technical parameters and minimum size of splashwell	pag . 3
— Technical information	pag . 3
— Minimum splashwell dimensions	pag . 3
— Hoses/fittings installation-pump connection	pag . 4
— Hydraulic hose installation	pag . 5
— Hydraulic hose / hose joint installation	pag . 6
— HSX-NR90/HSX-MR90 hydraulic steering system installation	pag . 7
— Steering pump HSX-NR90 installation	pag . 7
— Cylinder HSX-MR90 installation	pag . 9
— HSX-NR150/HSX-MR150 hydraulic steering system installation	pag . 11
— Steering pump HSX-NR150 installation	pag . 11
— Cylinder HSX-MR150 installation	pag . 13
— HSX-NR300/HSX-MR300 hydraulic steering system installation	pag . 15
— Steering pump HSX-NR300 installation	pag . 15
— Cylinder HSX-MR300 installation	pag . 17
— Refueling and venting of hydraulic steering system	pag . 19
— General faults and Solutions	pag . 21
— Maintenance	pag . 22

---

## General safety rules and warranty

This installation and maintenance manual is an integral part of the product and must be fully understood by the user before installation.

The installation, maintenance and transfer of hydraulic direction system components of NOERL series of products must be done by the authorized and qualified professional technicians. NOERL series of products implements the warranty for two years after-sales service, when using the product, If there is any question or problem, please contact the dealer in time. NOERL will provide the correct guidance. NOERL will not take responsible for the consequences of unauthorized dismantling or disassembling.

Without the prejudice to the nature of the product, NOERL has the rights to make changes to the description information and illustrations contained in this manual , NOERL does not assume any responsibility for the adverse consequences caused by coping this manual in any other illegal means which makes the user can't follow the standard installation instructions.

## Installation Precautions:

- Use components provided by NOERL only, The parts supplied by the other manufactures may cause safety hazards and affect the steering function;
- On all pipe connection threads, only seals such as Loctite PST or equivalent sealant should be used. Do not use (banding) or similar sealing tapes, as this may allow debris to enter the body of the pump and cause the blockage of the pipe .
- Please use 10 # or 15 # special hydraulic oil which is qualified and environment-friendly. Using other oil (such as brake oil) instead may cause irreparable damage to your equipment, causing loss of steering function and no warranty.
- The minimum bending radius of the pipe is 1 "18 (30CM). Do not touch the sharp objects. Continued bending, rubbing, scratching or twisting may cause the pipe to be damaged and rupture due to the normal steering pressure, thus causing loss of steering function.
- Do not let the pipe drop freely when using, please use wire or other PVC material to fix, so as to avoid potential safety hazard.
- Regular maintenance of system components and inspection of pipes and fittings for wear or damage can prolong the usage life of your equipment.

## Technical information:

TYPE	HSX-90HP	HSX-150HP	HSX-300HP
PUMPS	NR90	NR150	NR300
CAPACITY CM <sup>3</sup>	16	18	27
N°OF PISTONS	5	7	7
MAX PRESSION BARS	68	68	68
TURNS OF WHEEL	4.3	6.3	5.3
CYLINDERS	MR90	MR150	MR300
TUBE I.D[mm]	25	32	35
ROD I.D[mm]	14	15.8	18
OUTPUT FORCE/KGF	232	400	470
STROKE[mm]	200	198	214
VOLUME [cc]	73	118	141
APPLICATI ON	Up to 90HP	Up to 150HP	Up to 300Hp

## Minimum Splashwell Dimensions:

Before attempting installation, ensure that the splashwell of your boat has the following minimum dimensions.

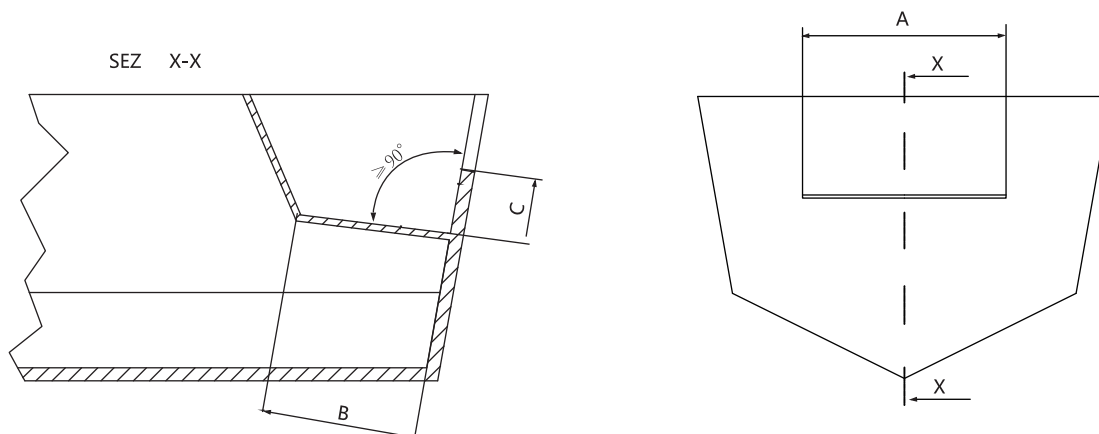

MINIMUM SPLASHWELL DIMENSIONS			
Number of engines	A	B	C
1	560mm-21.25"	152mm-5.98"	152mm-5.98"
2	1110mm-21.55"	152mm-5.99"	152mm-5.99"

**Hoses/fittings installation-pump connection**

Refer to illustrations below for the correct connection of hoses from helm pump to cylinder.

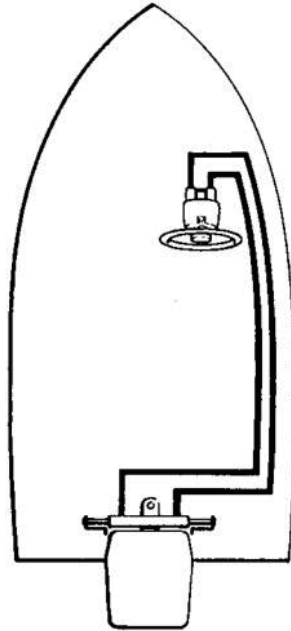

FOR HSX - MR 90 / 150 / 300

**Hose connection**

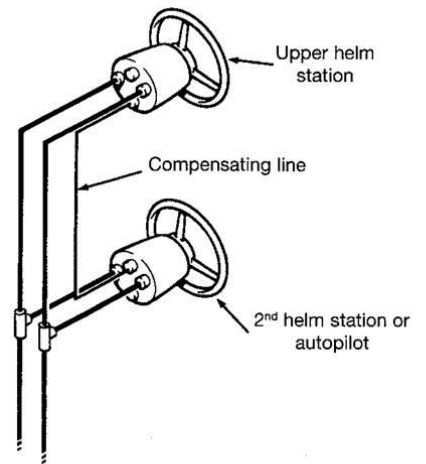
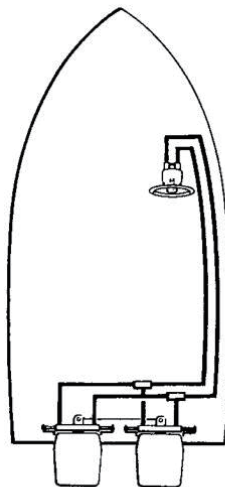
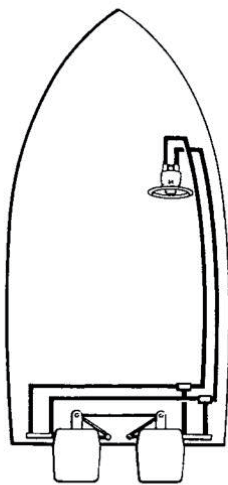

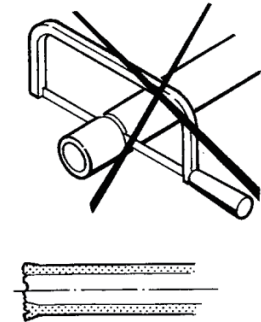
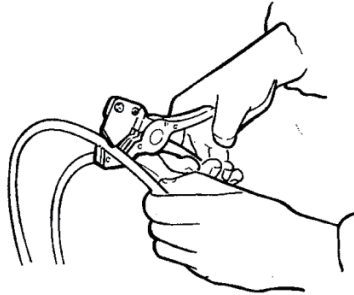
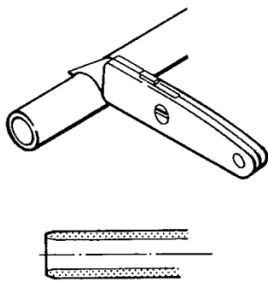
**Hose connection**

NOERL recommends the use of NOERL steering hoses only.

Always try to route the hoses via the shortest path in order to avoid any possible loss of power. In order to make the air bleeding of the system easier, it is suggested to mount the hoses horizontally with an inclination of about 3 cm per meter; the pump side has to be higher than the cylinder side.

Always protect the hoses which have to pass through a different compartement or use suitable bulkhead connectors or sleever.

Hose have to be installed in such a way they don't represent an obstacle for other components.

Do not remove protective end covers until the hoses have been routed and are ready to be connected to the helm pump, hose fitting or steering cylinder (s).

Provide sufficient hose lengths to allow for cylinder movement throughout the turning arc and up/down trim/tilt settings of the engine(s).

Throughout the hose installation, ensure the protective caps remain installed onto the end of the hoses.

**Attention:**

Do not install hoses in an area where they will be exposed to high heat. Extreme heat reduces the hose bursting pressure and can cause the hose melting. Exercise great cleanliness. Make sure that pipes and hoses are perfectly clean and free from swarf.

**Note:**

Flexible hoses have to be cut by means of a sharp knife; never use a saw, as fragments of nylon in the hydraulic system cause serious problems.

## Hydraulic hose installation

After cutting the nylon hose, fit the coupling nut and the support sleeve on the hose (check it is properly in relation to the end of the hose). After the mounting of the nut, you have to tight by means of a spanner.

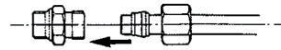
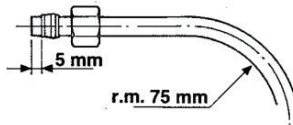

Otherwise, you can mount nylon flexible hose with recuperable fittings. Do as the illustrations below show.

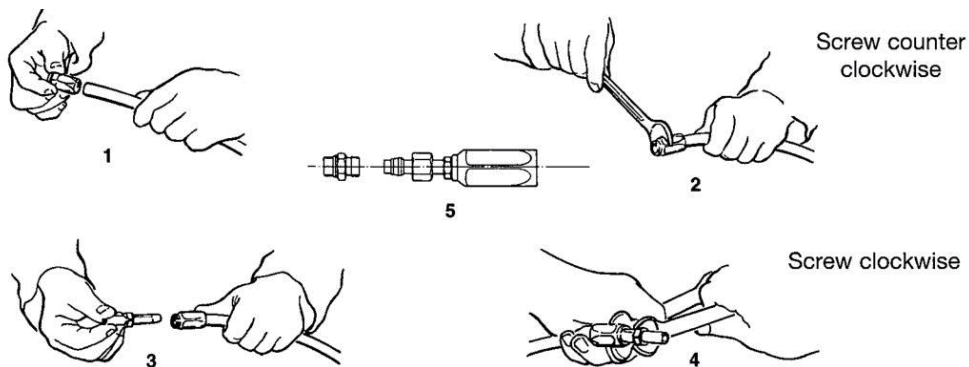

After the installation clean the inside of the hoses by blowing through using compressed air, in order to avoid any obstructions and to remove dust and debris from storage. Before the air bleeding it is also suggested to make a rinsing of the system. Do not use water.

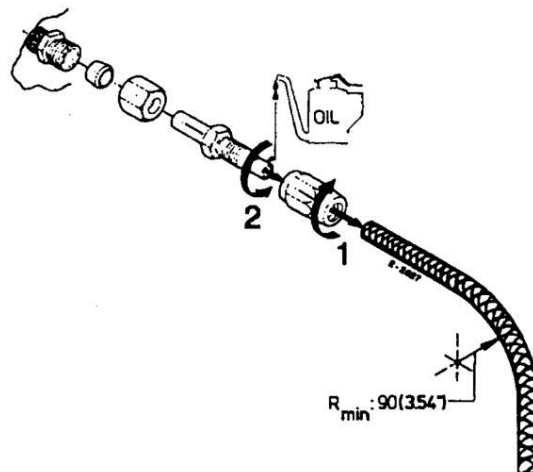

- 1 After cutting, screw the tube coupling sleeve onto the tubing (left-handed thread).
- 2 Oil the tube coupling and screw it into the sleeve. Make sure that the internal sheathing of the tubing does not follow while tightening the screw! Also make sure that the internal sheathing of the tubing is not squeezed while tightening the screw.
- 3 Check there is no internal interference putting a small screwdriver into the tube coupling before proceeding with hose installation to helm or cylinder.



## Hydraulic Direction System HSX-NR90 / HSX-MR90 Installation:

Installation Tools (To complete the installation of this system, you need the following tools):

- Hole saw with diameter of 3.189 " (81MM)
- 0.354 " (9MM) drill bit
- 1.181 " (30MM) mounting wrench
- 0.433 " (11MM) installation wrench
- 0.748 " (19MM) installation wrench
- 0.669 " (17MM) installation wrench
- 0.472 " (12MM) installation wrench
- 0.945 " (24MM) socket wrench

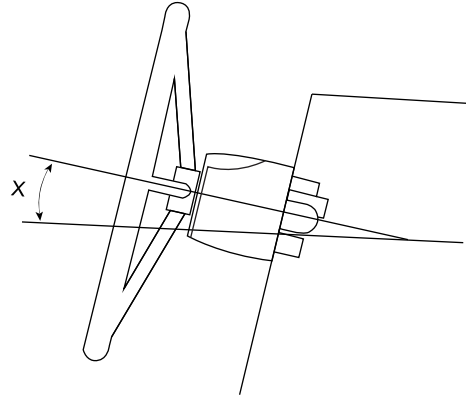

### Important:

perform the bleeding procedure manually and with the helm pump inclined no more of 10°(X).

## Steering pump HSX-NR90 Installation:

- Determine the angle and position you are installing to ensure that the steering wheel does not interfere with other equipment. Check that there is still sufficient space behind the bridge dashboard (2) for fitting and pipe connections.

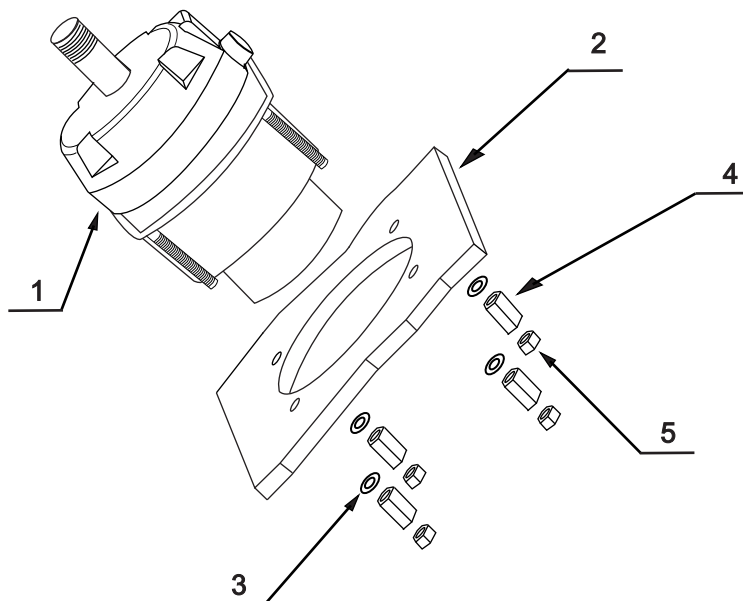

RIF.	QUANTITY	DESCRIPTION
1	1	pump
2	1	Board
3	4	Shim
4	4	Extension nut
5	4	Lock nut

- Attach a 1: 1 access hole mounting template (included with this manual) to the instrument panel, and position the mounting hole as standard with a hole cutter.
- Drill a 3.189 "(81MM) diameter hole and drill four 0.354 (9MM) diameter holes as shown on the mounting template.
- Route the arranged tubing through the middle 3.189 "(81mm) diameter hole and connect it to the steering pump (1).
- Install the steering pump on the instrument panel with 4 washers (3) and 4 strain-relief nuts (4), 4 lock nuts (5), tightening torque  $\leq 15$  N.
- Lubricate the taper section of the shaft. Install the semicircular key. Place the steering wheel in the direction shaft and the steering wheel keyway on the semicircular key. Place the shim and tighten the steering lock nut. The tightening torque is  $\leq 20$  Newton.

### Note:

- The steering pump should be mounted at a tilt angle of  $X \leq 20^\circ$ . If it is exceeded, it may cause air to enter the duct and affect the steering function.
- Only use self-locking fasteners provided by NOERL or standard fasteners. Using non-self-locking fasteners instead may cause the equipment to loosen or separate.
- Do not open the pump cover or filler cap when installing the steering pump to prevent dirt and chips from entering the pump and causing the steering function.
- Teflon-like ribbon seals can not be used on pipe nipples, which may cause tape chips to enter the pump body and thus affect the steering function. (The NOERL series is a pipe thread sealing technology that does not require the use of other sealing tape seals.)

**Cylinder HSX-MR90 Installation:**

**WARNING:**

It is important to check periodically, at least every 3 months (or every month for professional uses), the right torque of this bolt and of the locknut.

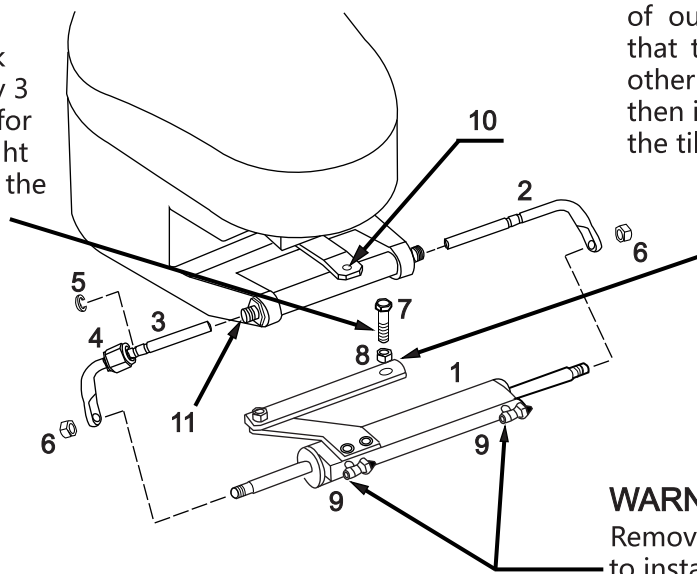

The cylinder arm should be attached of the engine tiller arm on most brands of outboards .in the event that the tiller interferes with other partts of the outboard, then it can be mounted under the tiller instead.

**WARNING:**

Remove the red caps in order to install the hose's fittings.

RIF.	QUANTITY	DESCRIPTION
1	1	Cylinder
2	1	Right support brackets
3	1	Left support brackets
4	1	Connecting nut
5	1	Stainless steel (C) buckle
6	2	Piston rod locking nut

RIF.	QUANTITY	DESCRIPTION
7	1	3/8 connecting bolt
8	1	3/8 Lock nut
9	2	Deflation device
10	1	Engine connecting block
11	1	Engine mounting hole

- Before attempting installation, make sure that your engine is adequate for this type of cylinder and make sure that your stern floor space is adequately sized for installation;
- Lubricate all articulated joints and piston rods with a qualified marine lubricant and center your engine;
- Loosen the self-locking nut (6) on one end of the piston rod, remove the right bracket without the connection nut (2), and install the left bracket (3) with the connecting nut on the other end into the mounting hole of the engine (11), Connect the nut (4). (If the space is limited, left / right brackets can be installed interchangeably without any adverse effect on the system)

- Unscrew the 3/8 bolt (7) in the middle hole of the stainless steel bracket in the cylinder and adjust the engine angle to match the corresponding hole, then connect the stainless steel bracket to the engine connecting block with the bolt (10), tighten the 3/8 self-locking nut (8) , And make sure the installation is correct
- Adjust the engine angle, install the removed bent rod without connecting nut (2) into the mounting hole of the engine and install it on the piston rod, tighten the self-locking nut (6) on both ends of the piston rod;
- Turn your engine and check that the installed fuel tank is running back and forth with and without interference components, readjust if there is interference, and pull your engine and fuel tank to the left / right limits if there is no interference for the subsequent refueling exhaust step;
- Connect the arranged tubing to the end of the tee with no bleed fitting (9) and tighten the corresponding bleeder and nut to prepare for subsequent filling and venting.

**Warning:**

When installing, to avoid bumping the piston rod, it is forbidden to hit the piston rod with wrench or anything hard. If the piston rod is bruised, it will cause hydraulic oil leakage of the oil cylinder, which will compromise your product experience.

## Hydraulic steering System HSX-NR150/HSX-MR150 Installation:

Installation Tools (To complete the installation of this system, you need the following tools):

- Hole saw with 3.03 " (77MM) diameter
- 0.354 " (9MM) drill bit
- 1.181 " (30MM) mounting wrench
- 0.433 " (11MM) installation wrench
- 0.748 " (19MM) installation wrench
- 0.669 " (17MM) installation wrench
- 0.472 " (12MM) installation wrench
- 0.945 " (24MM) socket wrench

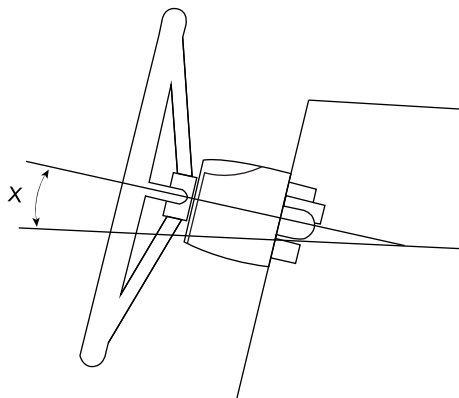

**Important:**

perform the bleeding procedure manually and with the helm pump inclined no more of 10°(X).

### Steering pump HSX-NR150 Installation:

- Determine the angle and position you are installing to ensure that the steering wheel does not interfere with other equipment. Check that there is still sufficient space behind the bridge dashboard (2) for fitting and pipe connections.

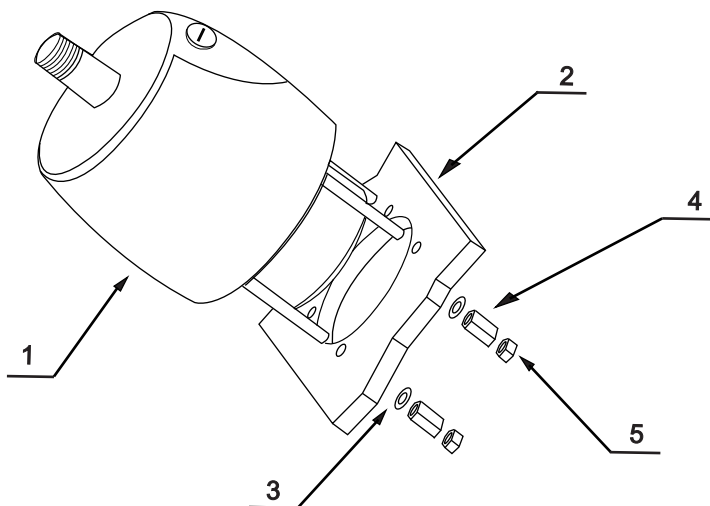

RIF.	QUANTITY	DESCRIPTION
1	1	pump
2	1	Board
3	4	Shim
4	4	Extension nut
5	4	Lock nut

- Attach a 1: 1 access hole mounting template (included with this manual) to the instrument panel, and position the mounting hole as standard with a hole cutter.
- Drill one 3.03 "(77MM) diameter hole and drill four 0.354 (9MM) diameter mounting holes, as shown on the mounting template.
- Route the good tubing through the middle 3.03 "(77mm) diameter hole and connect it to the steering pump (1).
- Install the steering pump on the instrument panel with 4 washers (3) and 4 extension nuts (4), 4 lock nuts (5), tightening torque  $\leq 15$  N.
- Lubricate the taper section of the shaft. Install the semicircular key. Place the steering wheel in the direction shaft and the steering wheel keyway on the semicircular key. Place the shim and tighten the steering lock nut. The tightening torque is  $\leq 20$  Newton.

### Note:

- The steering pump should be mounted at a tilt angle of  $X \leq 20^\circ$ . If it is exceeded, it may cause air to enter the duct and affect the steering function.
- Only use self-locking fasteners provided by NOERL or standard fasteners. Using non-self-locking fasteners instead may cause the equipment to loosen or separate.
- Do not open the pump cover or filler cap when installing the steering pump to prevent dirt and chips from entering the pump and causing the steering function.
- Teflon-like ribbon seals can not be used on pipe nipples, which may cause tape chips to enter the pump body and thus affect the steering function. (The NOERL series is a pipe thread sealing technology that does not require the use of other sealing tape seals.)

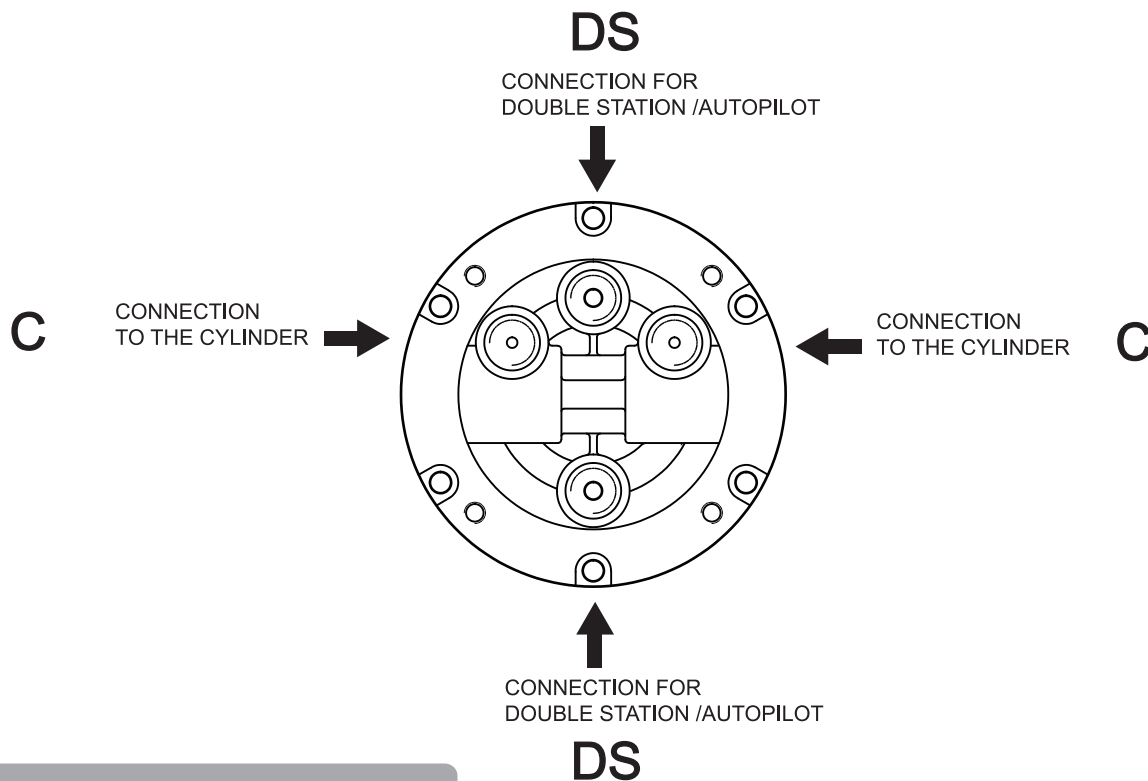

### VALVE PORTS CONNECTION:

Port marked "C": connections to the cylinder/s

Port marked "DS": connections to the additional station or autopilot

**Cylinder HSX-MR150 Installation:**

**WARNING:**

It is important to check periodically, at least every 3 months (or every month for professional uses), the right torque of this bolt and of the locknut.

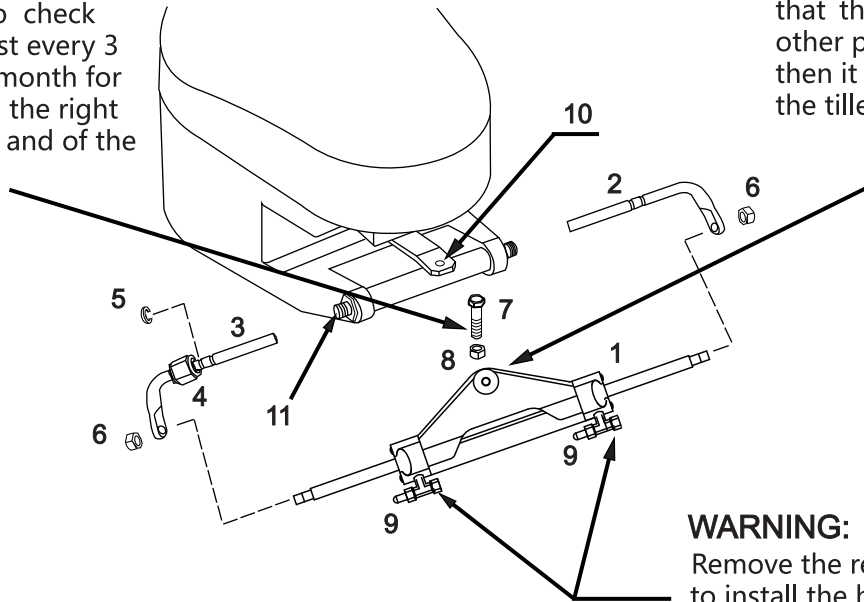

The cylinder arm should be attached of the engine tiller arm on most brands of outboards .in the event that the tiller interferes with other parts of the outboard, then it can be mounted under the tiller instead.

**WARNING:**

Remove the red caps in order to install the hose's fittings.

RIF.	QUANTITY	DESCRIPTION
1	1	Cylinder
2	1	Right support brackets
3	1	Left support brackets
4	1	Connecting nut
5	1	Stainless steel (C) buckle
6	2	Piston rod locking nut

RIF.	QUANTITY	DESCRIPTION
7	1	3/8 connecting bolt
8	1	3/8 Lock nut
9	2	Deflation device
10	1	Engine connecting block
11	1	Engine mounting hole

- Before attempting installation, make sure that your engine is adequate for this type of cylinder and make sure that your stern floor space is adequately sized for installation;
- Lubricate all articulated joints and piston rods with a qualified marine lubricant and center your engine;
- Loosen the self-locking nut (6) on one end of the piston rod, remove the right bracket without the connection nut (2) , and install the left bracket (3) with the connecting nut on the other end into the mounting hole of the engine (11) , Connect the nut (4). (If the space is limited, left / right brackets can be installed interchangeably without any adverse effect on the system)

## NOERL HSX-NR150/HSX-MR150 hydraulic steering system

- Loosen the 3/8 bolt (7) in the middle hole of the triangle bracket of the cylinder and adjust the angle of the engine to match the corresponding hole. Then connect the stainless steel bracket to the engine connecting block with the bolt (10) , tighten the 3/8 self-locking nut (8) , And make sure the installation is correct.
- Adjust the engine angle, install the removed bent rod without connecting nut (2) into the mounting hole of the engine and install it on the piston rod, tighten the self-locking nut (6) on both ends of the piston rod;
- Turn your engine and check that the installed fuel tank is running back and forth with and without interference components, readjust if there is interference, and pull your engine and fuel tank to the left / right limits if there is no interference, For the subsequent refueling exhaust step
- Connect the arranged tubing to the one end of the tee without bleed fitting , and lock the corresponding bleeder fitting nut to prepare for the subsequent refueling and venting.

### Warning:

When installing, to avoid bumping the piston rod, it is forbidden to hit the piston rod with wrench or anything hard. If the piston rod is bruised, it will cause hydraulic oil leakage of the oil cylinder, which will compromise your product experience.



## Hydraulic Direction System HSX-NR300 / HSX-MR300 Installation:

Installation Tools (To complete the installation of this system, you need the following tools):

- Hole saw with 3.03 " (77MM) diameter
- 0.354 " (9MM) drill bit
- 1.181 " (30MM) mounting wrench
- 0.433 " (11MM) installation wrench
- 0.748 " (19MM) installation wrench
- 0.669 " (17MM) installation wrench
- 0.472 " (12MM) installation wrench
- 0.945 " (24MM) socket wrench

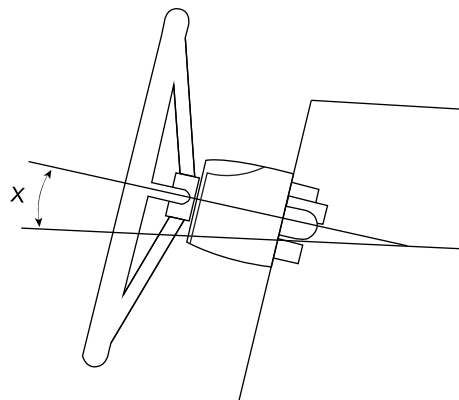

**Important:**

perform the bleeding procedure manually and with the helm pump inclined no more of 10°(X).

## Steering pump HSX-NR300 Installation:

- Determine the angle and position you are installing to ensure that the steering wheel does not interfere with other equipment. Check that there is still sufficient space behind the bridge dashboard (2) for fitting and pipe connections.

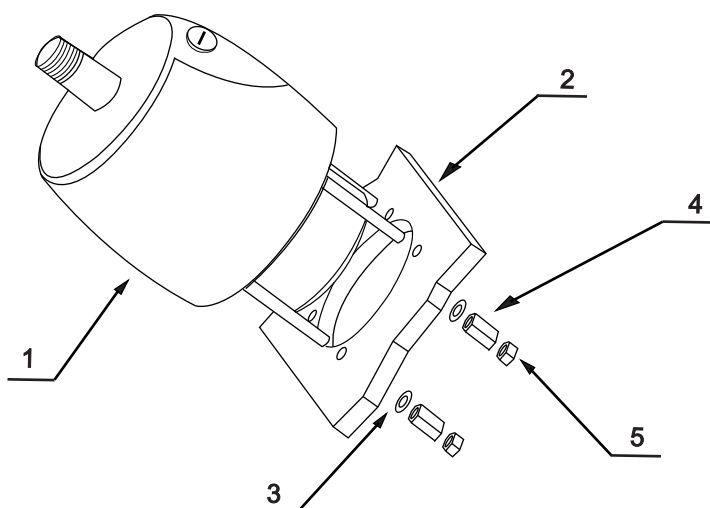

RIF.	QUANTITY	DESCRIPTION
1	1	pump
2	1	Board
3	4	Shim
4	4	Extension nut
5	4	Lock nut

## NOERL HSX-NR300/HSX-MR300 hydraulic steering system

- Attach a 1: 1 access hole mounting template (included with this manual) to the instrument panel, and position the mounting hole as standard with a hole cutter.
- Drill a 3.03 "(77MM) diameter hole and drill four 0.354 (9MM) diameter holes as shown on the mounting template.
- Route the arranged tubing through the middle 3.03 "(77mm) diameter hole and connect it to the steering pump (1).
- Install the steering pump on the instrument panel with 4 washers (3) and 4 strain-relief nuts (4), 4 lock nuts (5), tightening torque  $\leq 15$  N.
- Lubricate the taper section of the shaft. Install the semicircular key. Place the steering wheel in the direction shaft and the steering wheel keyway on the semicircular key. Place the shim and tighten the steering lock nut. The tightening torque is  $\leq 20$  Newton.

### Note:

- The steering pump should be mounted at a tilt angle of  $X \leq 20^\circ$ . If it is exceeded, it may cause air to enter the duct and affect the steering function.
- Only use self-locking fasteners provided by NOERL or standard fasteners. Using non-self-locking fasteners instead may cause the equipment to loosen or separate.
- Do not open the pump cover or filler cap when installing the steering pump to prevent dirt and chips from entering the pump and causing the steering function.
- Teflon-like ribbon seals can not be used on pipe nipples, which may cause tape chips to enter the pump body and thus affect the steering function. (The NOERL series is a pipe thread sealing technology that does not require the use of other sealing tape seals.)

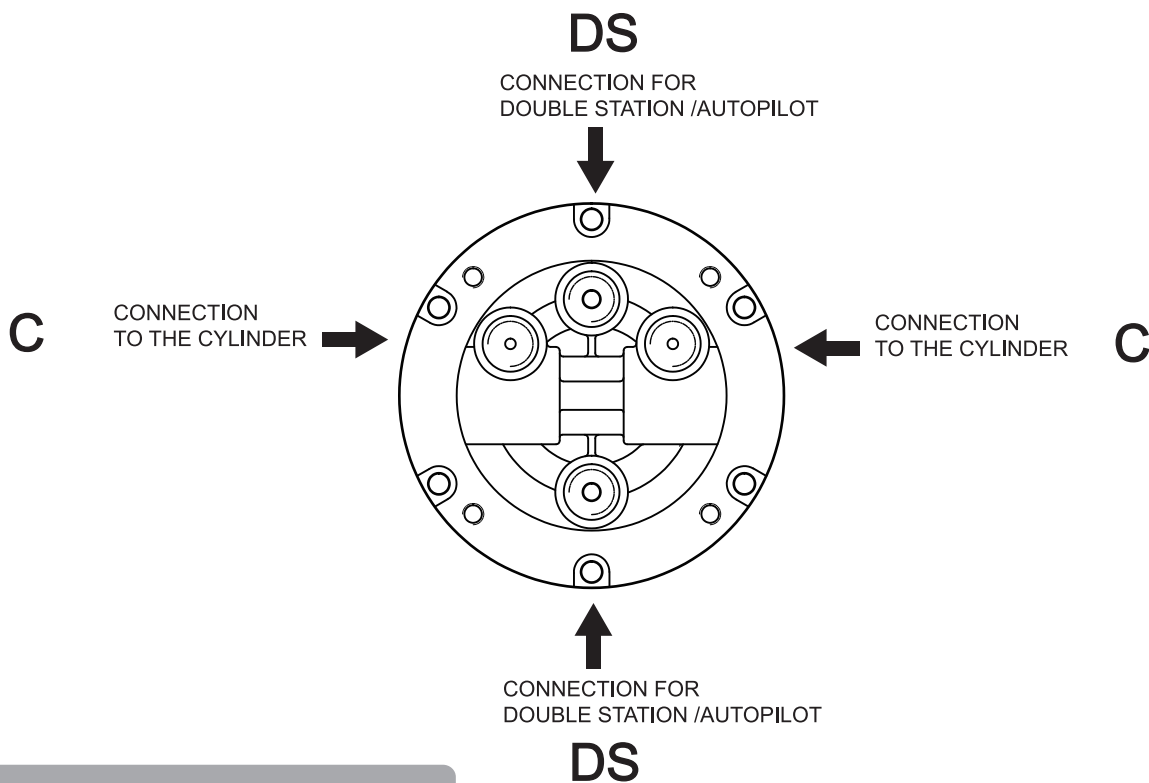

### VALVE PORTS CONNECTION:

Port marked "C": connections to the cylinder/s

Port marked "DS": connections to the additional station or autopilot

## Cylinder HSX-MR300 Installation:

### WARNING:

It is important to check periodically, at least every 3 months (or every month for professional uses), the right torque of this bolt and of the locknut.

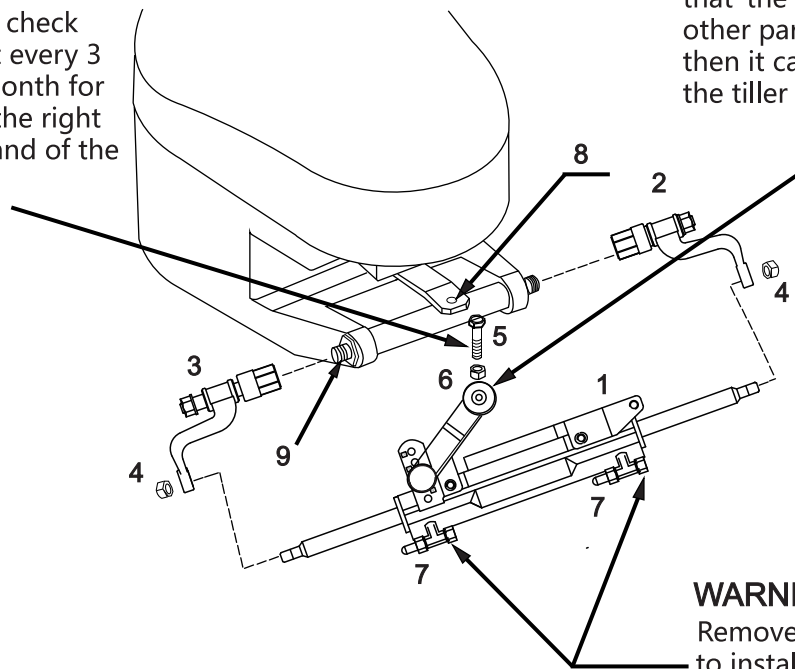

The cylinder arm should be attached of the engine tiller arm on most brands of outboards .in the event that the tiller interferes with other parts of the outboard, then it can be mounted under the tiller instead.

### WARNING:

Remove the red caps in order to install the hose's fittings.

RIF.	QUANTITY	DESCRIPTION
1	1	Cylinder
2	1	Right bracket assembly (short)
3	1	Left bracket assembly (long)
4	2	Piston rod locking nut
5	1	3/8 connecting bolt

RIF.	QUANTITY	DESCRIPTION
6	1	3/8 Lock nut
7	2	Deflation device
8	1	Engine connecting block
9	1	Engine mounting hole thread

- Before attempting the installation, make sure that your engine is adequate for this model cylinder and make sure that your stern plate is of sufficient size;
- Lubricate all moving connections and piston rods with qualified marine lubricants to prevent jamming and center your engine;
- Loosen the self-locking nut (4) on the left side of the piston rod, remove the long-bent rod assembly (3) on the left side, connect the short-bend rod assembly (2) on the right side to the mounting hole thread on the engine and fix it Good connection nut. (If the space is limited, the left / right bend assembly can be installed interchangeably without any adverse effect on the system)

- Unscrew the 3/8 bolt (5) of the middle stainless steel lubrication kit hole in the cylinder stainless steel bridge bracket and adjust the engine angle to match the corresponding hole and then use the bolts (5) Connect the stainless steel bracket to the engine connecting block (8) and tighten the 3 / 8 self-locking nuts (6), and make sure the installation is suitable.
- Adjust the engine angle and connect the connecting nut of the removed left elbow rod assembly (3) to the mounting hole thread (9) of the engine and install it on the piston rod to fix the connecting nut and tighten the self-locking nut (4); (for the installation of different models, the left side of the long curved rod assembly (3) connection nut in the curved bracket has a gap on the size of the phenomenon, the phenomenon of normal design, and will not affect your product experience.)
- Turn your engine and check that the installed cylinder is running back and forth with or without interference
- Connect the arranged tubing to the end of the tee with no bleed fitting (7), and tighten the corresponding bleeder fitting nut to prepare for subsequent filling and venting.

#### Warning:

When installing, to avoid bumping the piston rod, it is forbidden to hit the piston rod with wrench or anything hard. If the piston rod is bruised, it will cause hydraulic oil leakage of the oil cylinder, which will compromise your product experience.

### NOERL hydraulic direction of the system of gas exhaust:

This work procedure requires two people to operate, a person may not be able to completely remove all the air inside the hydraulic system which results in that the hydraulic system output pressure is not enough, the impact of weakness weakness, slow response, thus affecting your product experience .

Please use special eco-friendly hydraulic oil provided by NOERL or other qualified special hydraulic oil for refueling. Do not use brake oil. Using other unacceptable corrosive oil may cause irreparable damage to your system and result in the product being unable to be warranted .

#### Precautions:

- If you fill the pump with hydraulic fluid before connecting the filler tube to the pump, the filling procedure can be made more quickly and easily.
- In case of emergency, any non-toxic, non-corrosive, non-flammable oil can be temporarily supplied to the system, but the entire system must be thoroughly cleaned afterwards;
- Please keep refueling tube visible during the entire refueling process. Do not allow oil to enter the pump. Otherwise, air may be introduced to increase refueling time.
- During the process of refueling and exhausting, the hydraulic oil collected from the air bleeder manifold of the cylinder can be used directly after a few moments.
- Please protect the environment and properly dispose of used oil. The special hydraulic oil provided by NOERL system can be reused after being filtered by the filter with the hole diameter less than or equal to 38um.

### Refuiling and Venting Steps:

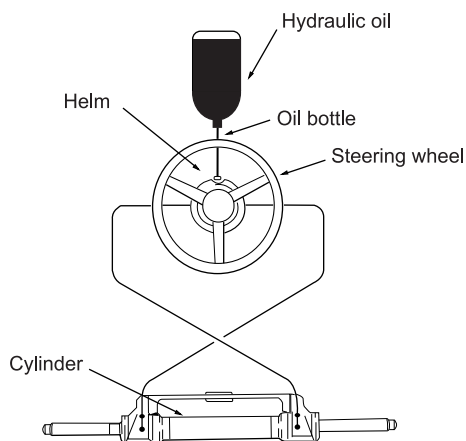

- Screw the fillet pipe thread equipped with the system into the fueling pump port and tighten to confirm airtight.
- Fit the sharp mount included with this system to the oil bottle cap. Insert the sharp mouth into the pump with some force, pour the oil into the fuel filler pipe until you can't see the air (the bottle can be squeezed gently to speed up refueling.)

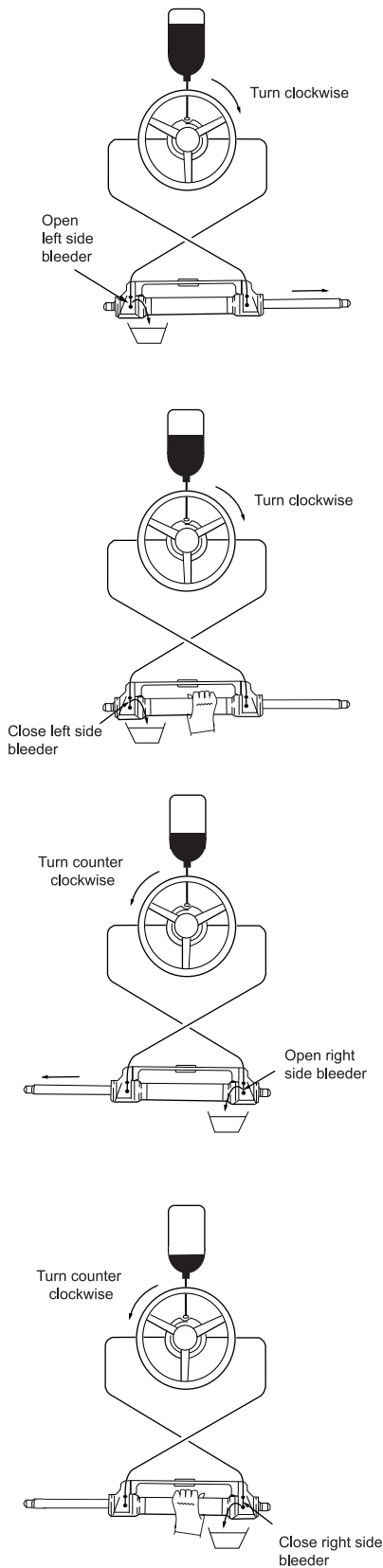

- Turn the steering wheel slowly clockwise until one side of the piston rod is fully extended. Fit the exhaust pipe to the retract side of the piston rod to collect the oil from venting.
- Hold the cylinder to prevent the cylinder from turning, unscrew the deflation nipple nested on the side of the bleeder, (do not unscrew it completely, it is enough if you can see the oil) turn the steering wheel clockwise until you see the inside of the exhaust pipe. Expelled oil is stable and thorough, no bubbles, turn the steering wheel at the same time tighten the deflation nut, close exhaust fittings;
- Continue to turn the steering wheel counterclockwise until the original retraction side of the piston rod fully extended, Fit the exhaust pipe to the retract side of the piston rod to collect the oil from venting.
- Hold the cylinder to prevent the cylinder from turning, unscrew the deflation joint nut of one side. ( Do not unscrew it completely, it is enough as long as you can see the oil ). Turn the steering wheel clockwise until you see the oil from the deflating pipe is stable, no bubbles, tighten the bleeder lock, close deflation devices.
- Rotate the steering wheel clockwise /counter clockwise several times to check the number of full helm turns (parameter table) to determine whether the hydraulic fluid in the tubing has been completely excluded. If there is still air, the number of full rudder will increase.) if there is still a lot of air that is not excluded, then repeat procedure(3) ~ (6). If there is a small amount of air, do full rudder in one direct, reverse small semi circle, do full rudder again, do this for 5-6 times for the left direction and right direction.
- After around rudder test pass, remove the fuel pipe and bleed pipe, screw the fuel cap, set the deflated connector sleeve, the unused hydraulic oil is closed for subsequent maintenance and repair. ( Check the hydraulic pump oil surface once a quarter, insufficient oil will cause something abnormal.)

## Faults and Solutions:

The following are the most common failures and their causes and solutions.

When the rudder rotates with full rudder (cylinder full stroke), there may be slight resistance and internal parts click sound which is from internal valve spool ball and bearing steel ball when they are running. It is normal phenomena. Please do not think it is caused by faults.

FAULT	CAUSE	SOLUTION
The hydraulic rudder is completely stuck during installation.	Pipe blockage between the hydraulic pump and hydraulic cylinder.	Check if the hose pipe is clogged or bent, If it is bent, you must replace the damaged hose, or it may result in the loss of steering and serious personal injury or property damage.
It is difficult to refuel the system, even when the system says the fuel is full, bubbles continue to pop out from the oil pump.	<ul style="list-style-type: none"> <li>• There is air in the system</li> <li>• Bleed fitting leaks</li> <li>• Hydraulic piping has winding or bending injuries.</li> </ul>	<ul style="list-style-type: none"> <li>• Install the system properly according to the installation manual. The inlet pipe must be always upward.</li> <li>• Tighten the deflation fittings.</li> <li>• Unwind and straighten the hose or replace the damaged hose.</li> </ul>
When using the system to steer, you need to rotate the full rudder quickly for many times.	<ul style="list-style-type: none"> <li>• Hydraulic piping has bent injuries</li> <li>• There is gas or fine bubbles in the hydraulic oil.</li> <li>• Incorrect hydraulic oil was used.</li> </ul>	<ul style="list-style-type: none"> <li>• Unwind and straighten the hose or replace the damaged hose.</li> <li>• Refuel or exhaust properly according to the installation manual.</li> <li>• Use the correct hydraulic oil</li> </ul>
When the system is full rudder, the steering wheel just doesn't work.	There are dirt impurities in the hydraulic pump valve	<ul style="list-style-type: none"> <li>• Do not use the "band" sealing tape at the interface.</li> <li>• Take apart the hydraulic pump to clean the dirt.</li> </ul>
The system can steer the ship easily when the ship is stationary, However, it is very difficult to steer while sailing.	<ul style="list-style-type: none"> <li>• Small steering wheel was selected.</li> <li>• Engine connection is not set correctly,</li> <li>• Airbag is generated in the system and air is not excluded completely.</li> <li>• System configurations exceed power limits.</li> </ul>	<ul style="list-style-type: none"> <li>• Change to a bigger steering wheel of which the maximum diameter is without exceeding 56cm.</li> <li>• Adjust the engine connection settings correctly.</li> <li>• Check the oil surface of hydraulic pump, reset the refueling and venting correctly.</li> </ul>
Steering wheel turns to left port side, Ship turns right	Wrong oil pipe connection	Swap the two oil pipes of the cylinder with each other and install them.
Cylinder can not be installed to the engine.	Each cylinder requires corresponding engine model.	Please refer to the manual or the customer service of the dealer to change the model.

When the rudder pump reaches the stop point (cylinder full stroke), a small amount of hydraulic drift is normal and the rudder pump is not 100% locked.

## Maintenance

### Warning:

Following the routine maintenance schedules as outlined below , in the time frame noted will ensure years of service from your NOERL Steering system as well as keep you and your passengers safe from the dangers that are present on and off water.

Failure to comply with maintenance checks may result in loss of steering , causing property damage and / or personal injury.

Inspections are necessary every year and must be carried out by specialized marine mechanics .

Check the shaft and the orings of the cylinder , the orings of the helm pump , the fittings of the cylinder and helm pump in order to prevent leaks .

Check tightness of all fasteners/fittings throughout the steering system .

Clean the system using fresh water and non-abrasive liquid .

Cleaning fluids containing ammonia , acids or any other corrosive ingredients must not be used for cleaning any parts of the hydraulic steering system .

DO not use brake oils or automatic transmission fluid (ATE ) . Use only compatible hydraulic oils .

### Prior to every use:

- Check Fluid level in highest helm pump
- Verify immediate steering response when turning steering wheel(s)  
( Ensure engine turns when steering wheel is turned ) .
- Visually inspect all steering hoses and fittings for wear , kinking and / or leaks .
- Check for binding , loose , worn or leaking steering components .

### Warning :

DO NOT operate boat if any component is not in proper working condition .

In this case, please take photos immediately and contact your dealer .

After first 20 hours , then every 100 hours or 6 months thereafter ( which ever comes first ) :

- All points noted above
- Check tightness of ALL fasteners/fittings throughout the steering system . Tighten to correct torque specifications are required .
- Check for mechanical play or slop throughout steering system , correct as required .
- Check for signs of corrosion . If corrosion is present contact your dealer .

After every 200 hours or 12 months ( which ever comes first ) :

- All points noted above .
- Remove support rod from engine steering/tilt tube. Clean engine steering/tilt tube and re-grease using a good quality marine grease .
- Grease support rod liberally .
- Grease all contact points shown in the cylinder and tiebar installations.  
DO NOT remove tiller bolt to re-grease .
- Remove steering wheel and re-grease wheel shaft using a good quality marine grease .
- Inspect hydraulic oil for cleanliness , flush if required .

Any work being performed with the steering system MUST be completed by a qualified mechanic with the working knowledge of the system .



